



# V1667 & V1667/SY

Multistandard PAL/NTSC to SDI – 12 Bit Conversion -  
with Optional Synchroniser

## FEATURES

- Multistandard PAL & NTSC formats
- 12 bit conversion
- Spatio temporal adaptive decoding
- Minimal cross colour
- Very low unsuppressed subcarrier
- Processing delay <math>< 8\mu\text{S}</math>
- Excellent 'poor signal handling'
- 4 SDI outputs
- Optional synchroniser sub-module
- Adjustable offset delay
- Pulse output for audio tracking

HIGH PERFORMANCE  
ADAPTIVE, MULTI-  
STANDARD, COMPOSITE  
VIDEO DECODER



The V1667 accepts a single PAL or NTSC input and provides four component serial digital outputs. Apart from the additional two SDI outputs, the V1667 differs from the V1663 in having a greater conversion resolution of 12 bit as opposed to 10 bit. The decoding mode is varied pixel by pixel and an adaptive control system provides the optimum decoding algorithm for each picture point. The full horizontal luminance response is maintained and there is no loss in the vertical luminance response while the characteristics of the comb filter ensure minimal loss in the luminance diagonal response. Complementary luminance, chrominance separation ensures optimum performance when re-encoding decoded signals and a wide chrominance horizontal bandwidth is optimised for 4.43MHz and 3.58MHz subcarrier systems. The Adaptive, Spatio-Temporal Comb Filter gives full vertical chrominance resolution whilst providing very low levels of cross-colour in all picture conditions. In addition optimised characteristics ensure very low levels of unsuppressed colour subcarrier on stationary and moving pictures at all colour saturation levels. The lack of an inherent line (or frame) of delay combined with a low insertion delay (approx. 7.6  $\mu\text{S}$ ) simplifies system integration. EDH checksum generation is included as standard.

The V1667/SY is an adaptive, multi-standard, composite video Decoder with Frame Synchroniser. It accepts a single PAL or NTSC input and provides four component serial digital outputs locked to an external analogue Black and Burst or Video reference. Looped inputs are provided on both the Video and the Reference input. The output timing may be adjusted with respect to the Reference by up to +/- 127 lines with a resolution of 37ns. A delay output pulse (TTL) is provided to drive an external audio tracking device such as the V1635.

The standard V1667 may be upgraded to a V1667/SY by addition of a V16SY sub-module. Alternatively, submodule type V16SY-VHS may be fitted which has the additional benefit of producing a stable SDI output from a composite PAL/NTSC VHS tape recorder.

# V1667 & V1667/SY

## Multistandard PAL/NTSC to SDI – 12 Bit Conversion - with Optional Synchroniser

### Technical Specification

#### Analogue Input Loop

Format	PAL I, M, N, NTSC, NTSC Japan, NTSC 4.43
Level	1V p-p composite (terminated)
Connector	BNC
Impedance	75 ohms (external)
Return loss	>35dB to 5.5MHz

#### Serial Outputs (4)

Format	EBU Tech.3267 ANSI/SMPTE T14.22/082
Data rate	270Mb/s
Connector	BNC
Impedance	75 ohms
Return loss	>15dB, 5-270MHz
Amplitude	800mV p-p (terminated)
D.C. offset	0V +/- 0.5V
Rise and fall times	0.75 - 1.5ns
Drive capability	Up to 250m (Belden 8281)

#### Video Performance

Frequency response	+/- 0.2dB to 5MHz
Luminance non-linearity	<1.5%
Chrominance non-linearity	<1.5%
2T pulse response	<1%K
2T bar response	<0.5%K
50/60Hz square wave response	<0.5%K
Luma/chroma timing error	<10ns
Subcarrier rejection	>50dB
Signal to noise ratio	>70dB weighted

#### Frame Synchroniser - (/SY)

Output offset range with respect to reference	+/- 127 lines (resolution 37ns)
---	---------------------------------

#### Delay Indicator

Level	TTL
Connector	BNC
EDH generator	Inserts full field and active picture checksums in SDI

#### Ordering Information

V1667	Dual SDI to PAL/NTSC/YC
V1667/SY	Dual SDI to PAL/NTSC/YC with synchroniser

All Pro-Bel's quoted prices for interface modules include the supply of one suitable rear module. Please specify type required when placing order.

V16VR3B	3RU
V16VR1B	1RU

Note: Special versions of rear module are available on request.

#### Controls

Video gain	0% to 200% in 0.2% steps (Cal=100%)
Chroma gain	0% to 200% in 0.2% steps (Cal=100%)
Black level	+100mV to -100mV in 0.75mV steps
Phase adjustment	+45° to -45° in 0.3° steps
Input select	PAL B, G, I, M, N, NTSC M, J, 4.43, Auto
<b>Additional for SY</b>	
V timing offset	+/- 127 lines
H timing offset	+/- 1/2 line
IP fail mode	Freeze
Minimum delay mode	Freeze for 3s then cut to black On/Off

#### What is VisLock?

VisLock is a patented method of converting an NTSC composite analogue signal to serial digital form then subsequently re-converting back to NTSC with negligible loss of picture quality. This enables digital and analogue plant to be mixed in a high quality installation.

#### How does it work?

When a composite NTSC signal is decoded it is split into its luminance and colour difference components. This process is never perfect, even using the highest quality decoders, in practice some of the luminance picture information passes into the colour difference path. This results in spurious colour effects known as cross-colour. Also some of the subcarrier used to convey the colour information in the original NTSC inevitably passes into the decoded luminance. This may appear as a moving dot pattern on vertical edges of coloured areas or hanging dots on horizontal edges.

When the signal is re-encoded back to NTSC these effects may be increased in the final signal and loss of both luminance and chrominance resolution may also occur. The result is that the picture often looks blurred, captions become difficult to read and luminance detail may be masked by dramatic false colour effects.

In the decoder the VisLock system embeds subliminal data information into its serial digital output. This data passes with the video signal to downstream encoders and provides them with the information about the original NTSC signal. By using this information the encoder can re-assemble the NTSC signal exactly in the same way as it was separated.

In this way any spurious colour effects are transformed back into the original luminance detail. Any subcarrier which passes through luminance path is also added back to the NTSC output where it restores the colour resolution. The result is an NTSC output virtually indistinguishable from the original even after many repeated conversions.

#### Does the added data degrade my signal?

The data is also transmitted at very low level which makes it invisible to the viewer in the digital image. Also the serial data signal conveys 720 luminance samples in each picture line, the NTSC signal is slightly narrower and only occupies about 710 samples. The VisLock system embeds data only at the extreme edges of the digital signal so that it does not conflict with the decoded picture signal. The signal is only present in images from NTSC sources.

#### What about other equipment in the digital path?

Because the VisLock data is contained within the picture information it is transmitted accurately through most professional digital video plant including switchers, routers, synchronizers, audio embedders and de-embedders, caption and logo inserters etc.

#### How is VisLock Implemented?

The V1667 decoder and V1668 encoder modules are now available with VisLock, no additional equipment is required. The V1667 decoder converts the NTSC to serial digital (SDI) format and inserts the VisLock data. When the serial digital signal is subsequently converted back to NTSC in a VisLock compatible V1668 encoder the added data is read and the signal timed to ensure that optimum encoding quality is achieved and the signal timed to the genlock reference signal.

#### And the Result?

Really clean multiple conversions. Vistek has always been a world leader in the design of sophisticated decoders, and VisLock extends that design lead. When coupled with the exceptionally clean decoding of the 12 bit V1667, and the equally artefact-free encoding of the V1668, the resulting images are better than any other coder/decoder combination.

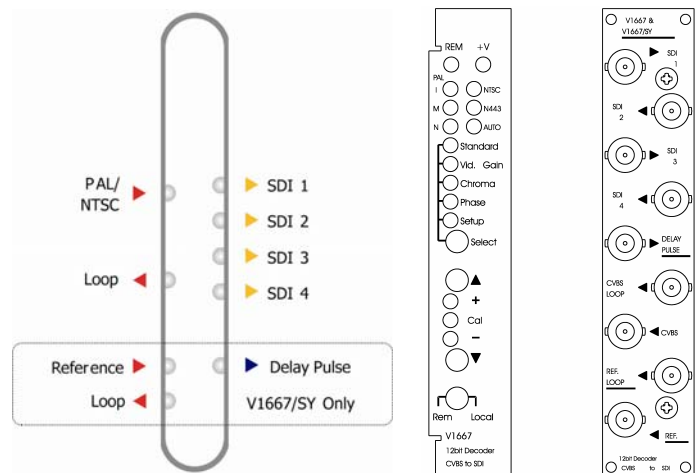

WWW.PRO-BEL.COM

UK +44 (0) 1189 866 123 USA +1 631 549 5159 France +33 (0) 1 45 18 39 80

